

# The Intimidator® ManLock Installation Instructions

For Use With McGard 5/8"-11 or 1/2"-13 Flat Seat Manlocks.

ie. 5/8"-11 thread: p/n 117151 (steel), p/n 127004 (stainless)  
 1/2"-13 thread: p/n 117150 (steel), p/n 127005 (stainless)

**• ATTENTION •**

Since all covers & frames can differ dimensionally, prior to start of this procedure each must be inspected to assure proper installation. This instruction sheet is meant to be a general guideline. Please call with any questions you may have during retrofit.

**STEP 1:** Secure Cover to Frame. If necessary, place wood wedges, tapered pins, or chisels between cover and frame to hold cover in place during drilling.

**STEP 2:** Drill 17/32" (for 5/8"-11 thread) or 7/16" (for 1/2"-13 thread) hole through COVER AND FRAME. (Approximately 3" minimum drill depth required to create hole through cover and frame. See Figure 2)

- Drill location approximately 5/16" from edge of cover. (See Figure 1)

**STEP 3:** Counterbore 1-1/4" diameter to 3/4" depth. (See Figure 3)

- NOTE: Counterbore depth of 3/4" minimum required to ensure protective cap will be below top of cover when installed. Counterbore depths less than 3/4" will result in protective cap protruding above cover.

**• IMPORTANT NOTICE •**

When drilling the counterbore, the bit must not go completely through the cover. Bolt seating area must be on the cover (See Section A, Figure 3).

**STEP 4:** Drill Clearance Hole thru Cover ONLY for bolt.

- Use 3/4" drill for 5/8"-11 thread, use 5/8" drill for 1/2"-13 thread.

**STEP 5:** Tap Hole in Frame.

- 5/8"-11 UNC class 2A thread for 17/32" hole.
- 1/2"-13 UNC class 2A thread for 7/16" hole.

**NOTE:** McGard recommends the use of a **ELECTROMAGNETIC DRILL** for ALL Drilling, Tapping and Counterbore Operations.

**STEP 6:** Repeat Steps 2 thru 5 for a second bolt to secure cover. Second hole should be 170° from first hole. (See Figure 1, marked "X")

**STEP 7:** Clean Tapped Hole with Compressed Air.

**STEP 8:** GREASE THREADS of MANLOCK BOLTS. VERY IMPORTANT!

**STEP 9:** Using Key Wrench install bolts to 75-90 ft-lbs of torque. (Approximately the same torque used on wheel lug nuts)

**STEP 10:** Install protective plastic caps **HAND TIGHT** to complete installation.

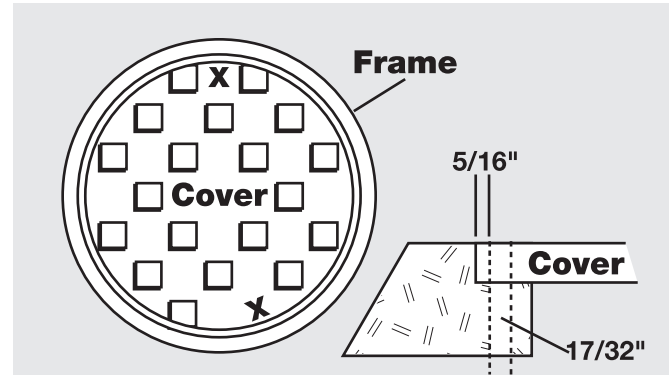

Figure 1

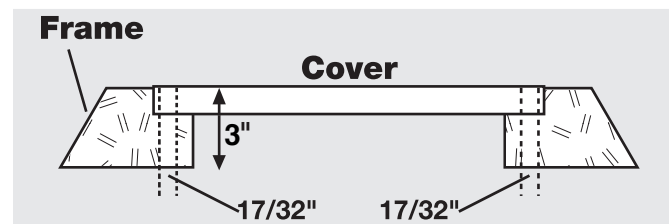

Figure 2

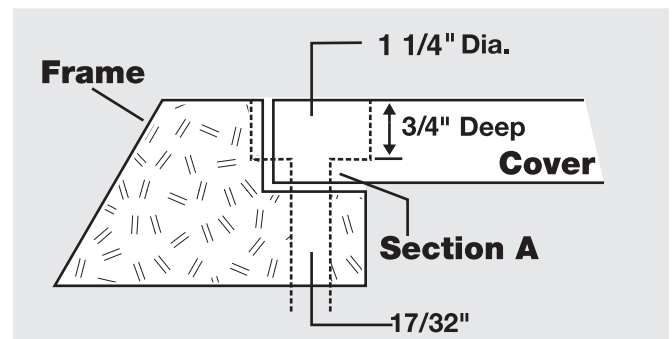

Figure 3

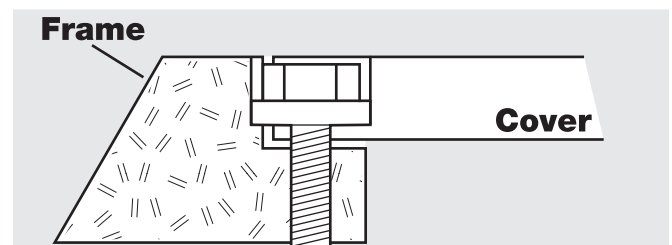

Figure 4

**• NOTE •**  
 Caps are included with all McGard flat seat ManLocks.



3875 California Road  
 Orchard Park, New York 14127-4198  
 888-888-9192 • fax: 716.662.8985

The Intimidator®  
 Line Of Security Products