

The Intimidator® ManLock Installation Instructions

For Use With McGard 5/8"-11 or 1/2"-13
Taper Seat Manlocks.

ie. 5/8"-11 thread: p/n 117011 (steel), p/n 117499 (stainless)
1/2"-13 thread: p/n 117069 (steel), p/n 127003 (stainless)

• **ATTENTION** •

Since all covers & frames can differ dimensionally, prior to start of this procedure each must be inspected to assure proper installation. This instruction sheet is meant to be a general guideline. Please call with any questions you may have during retrofit.

STEP 1: Secure Cover to Frame. If necessary, place wood wedges, tapered pins, or chisels between cover and frame to hold cover in place during drilling.

STEP 2: Drill 17/32" (for 5/8"-11 thread) or 7/16" (for 1/2"-13 thread) hole through COVER AND FRAME (Approximately 3" minimum drill depth required to create hole through cover and frame. See Figure 2)

- Drill location approximately 5/16" from edge of cover. (See Figure 1)

STEP 3: Counterbore 1-1/4" diameter to 1/2" depth, NOT including taper. (See Figure 3)

- NOTE: Counterbore depth of 1/2" minimum required to ensure protective cap will be below top of cover when installed. Counterbore depths less than 1/2" will result in protective cap protruding above cover.

- Counterbore Tools can be purchased through McGard.
P/N 166003 for 5/8"-11 thread, P/N 166002 for 1/2"-13 thread

• **IMPORTANT NOTICE** •

When drilling the counterbore, the bit must not go completely through the cover. Bolt seating area must be on the cover and is permissible on the frame (See Section A, Figure 3).

STEP 4: Drill Clearance Hole thru Cover ONLY for bolt.

- Use 3/4" drill for 5/8"-11 thread, use 5/8" drill for 1/2"-13 thread.

STEP 5: Tap Hole in Frame.

- 5/8"-11 UNC class 2A thread for 17/32" hole.
- 1/2"-13 UNC class 2A thread for 7/16" hole.

NOTE: McGard recommends the use of a **ELECTROMAGNETIC DRILL** for ALL Drilling, Tapping and Counterbore Operations.

STEP 6: Repeat Steps 2 thru 5 for a second bolt to secure cover. Second hole should be 170° from first hole. (See Figure 1, marked "X")

STEP 7: Clean Tapped Hole with Compressed Air.

STEP 8: GREASE THREADS of MANLOCK BOLTS. VERY IMPORTANT!

STEP 9: Using Key Wrench install bolts to 75-90 ft-lbs of torque. (Approximately the same torque used on wheel lug nuts)

STEP 10: Install protective plastic caps **HAND TIGHT** to complete installation.

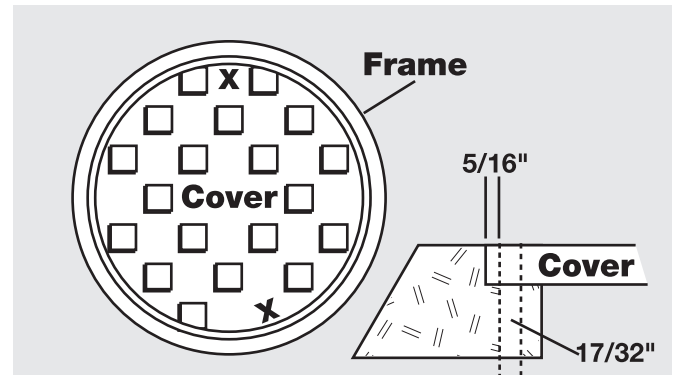

Figure 1

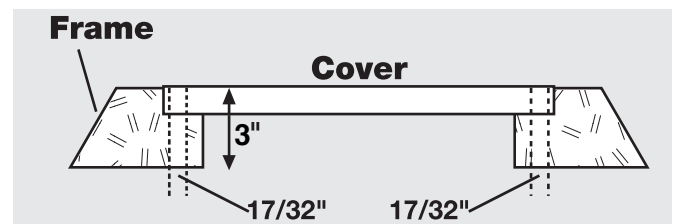

Figure 2

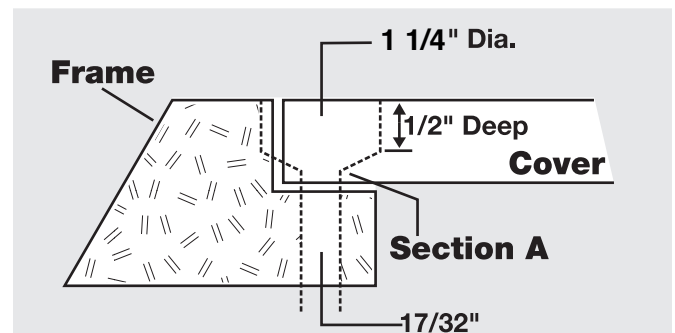

Figure 3

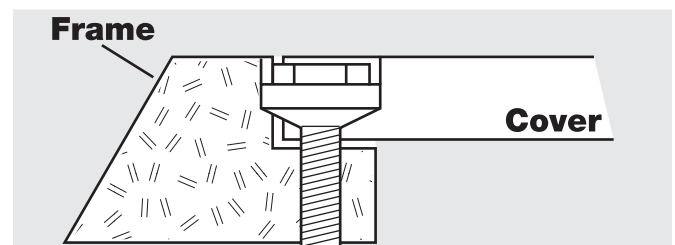

Figure 4

• **NOTE** •

Caps are included with all McGard taper seat ManLocks.



3875 California Road
Orchard Park, New York 14127-4198
888-888-9192 • fax: 716.662.8985

The Intimidator®
Line Of Security Products